



## EF

### AXIAL BATHROOM FANS / **Decoratife**

The front panel is thin and tight. This feature provides a robust mounting design. It is silent and corrosion resistant. Long life of the motor against environmental factors. Thermal protection.

Can be mounted on glass and wall.  
It is used for small volume spaces, bath and toilet ventilation.

#### Technical Drawing and Tables

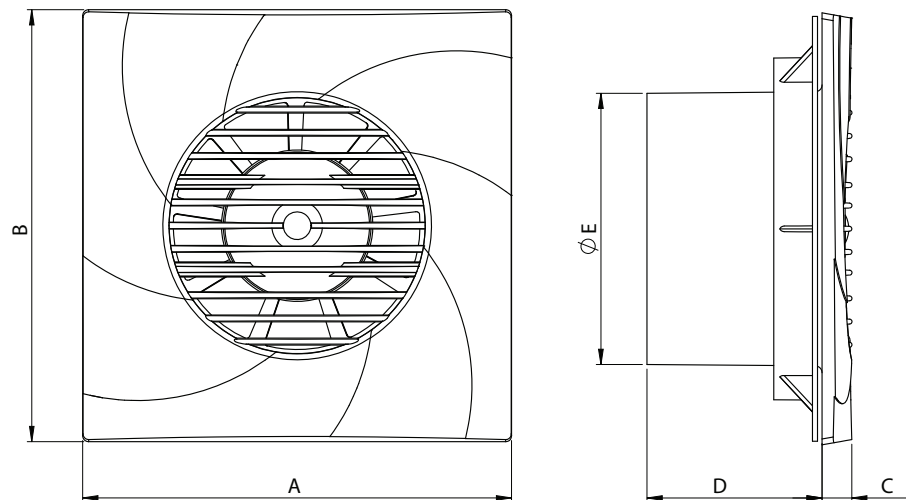

TYPE	A	B	C	D	E
EF 1009	160	160	12	70	97,5
EF 1219	188	188	14	76	118
EF 1530	208	208	14	118	145

Dimensions are in (mm)

TYPE	VOLTAGE	FREQUENCY	POWER	CURRENT	CAPACITOR	SPEED	AIR FLOW	SOUND PRESSURE	INSULATION CLASS	PROTECTION CLASS	WEIGHT	PIECES IN BOX
	V	Hz	W	(A)	( $\mu$ F)	r.p.m	m <sup>3</sup> /h	dB(A)	Ins.cl.	IP	kg	AD
EF 1009	230	50/60	13	0,09	-	2600	100	40	B	20	0,5	24
EF 1219	230	50/60	14	0,09	-	2400	200	41	B	20	0,55	20
EF 1530	230	50/60	21	0,13	-	2000	300	43	B	20	0,71	16

Sound Level Measured from 3m distance in room condition.

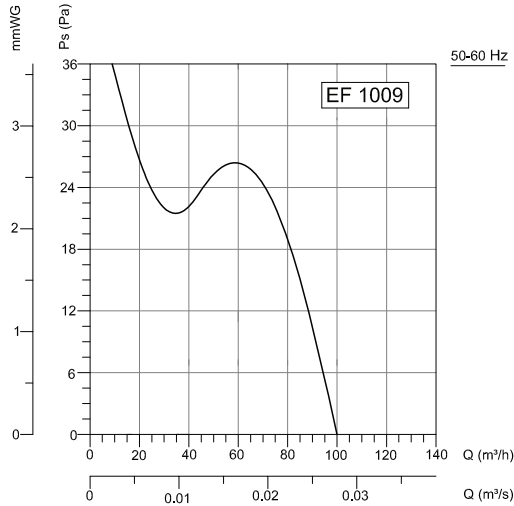

Frequency	Tot	63	125	250	500	1000	2000	4000	8000	Hz
L <sub>WA</sub> Inlet	47	11	35	41	43	40	36	34	27	dB(A)
L <sub>WA</sub> Outlet	56	36	49	52	52	42	38	34	25	dB(A)

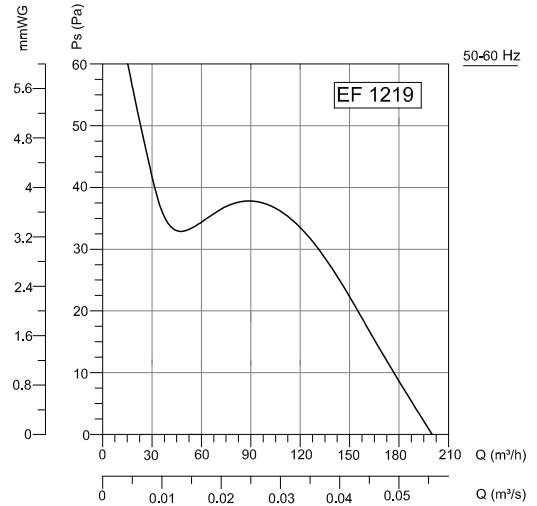

Frequency	Tot	63	125	250	500	1000	2000	4000	8000	Hz
L <sub>WA</sub> Inlet	48	15	41	42	41	40	38	31	24	dB(A)
L <sub>WA</sub> Outlet	59	56	52	53	50	43	40	29	22	dB(A)

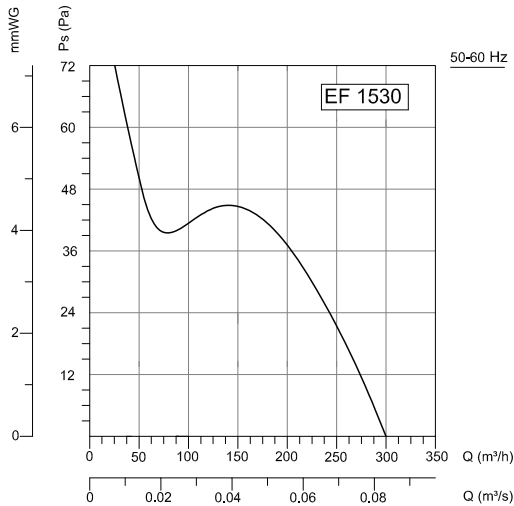

Frequency	Tot	63	125	250	500	1000	2000	4000	8000	Hz
L <sub>WA</sub> Inlet	50	18	37	45	45	43	40	33	25	dB(A)
L <sub>WA</sub> Outlet	57	36	49	55	49	40	40	32	20	dB(A)

### Accessories



BSC

